



ALMA MATER STUDIORUM
UNIVERSITÀ DI BOLOGNA

2nd year – students meeting

International Master's Degree in
Artificial Intelligence

Planning your 2nd year

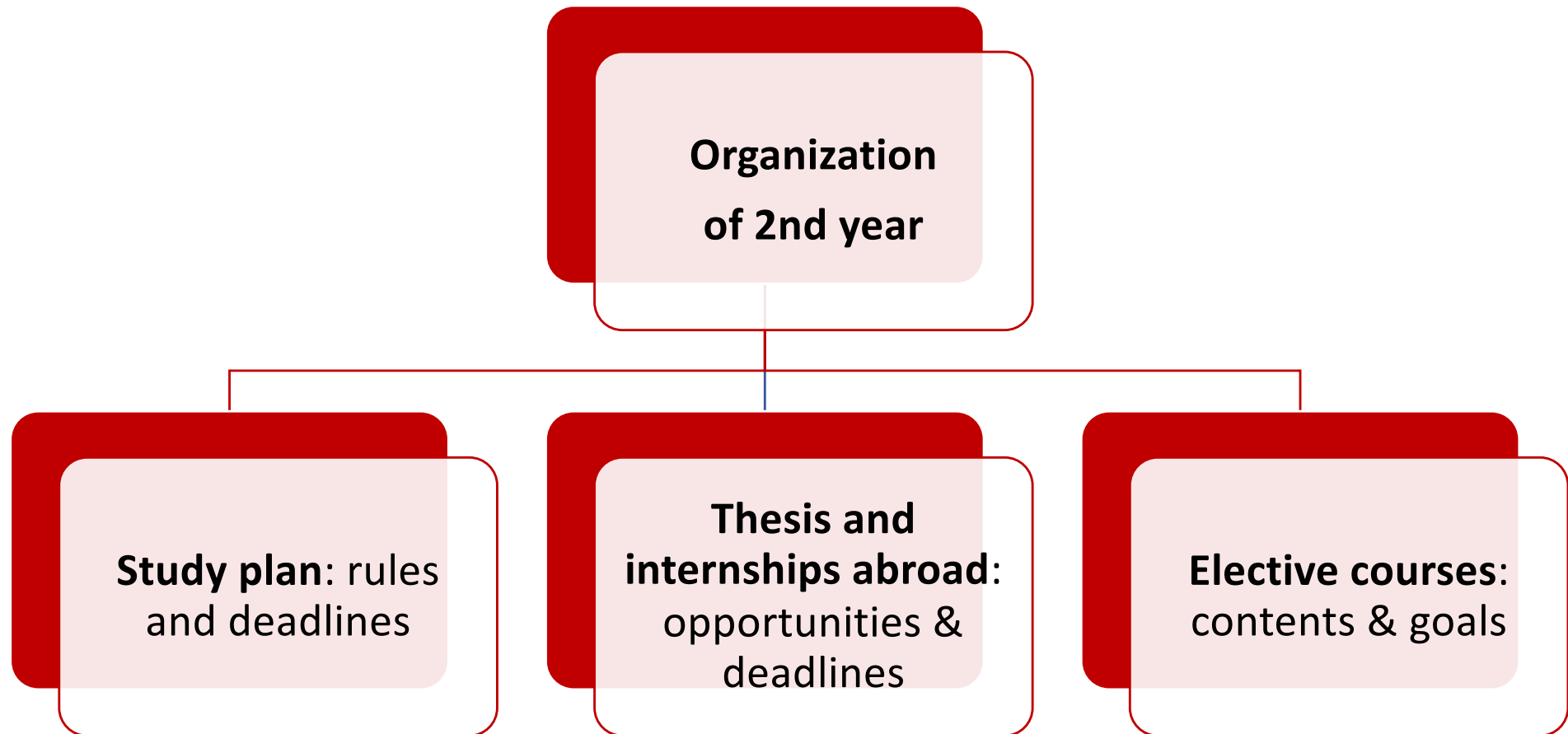

Organization of 2nd year



5 groups of learning activities, totalling 60 cfu:

- Two mandatory courses: NLP and Ethics in AI (12 cfu)
- C: One course among those listed (6 cfu)
- D: Two “freely” chosen courses (12 cfu)
 - *Automatically approved*: activities from previous group and other activities presented later today
 - *Subject to approval*: any other courses taught at UNIBO in English
 - *Not approved*: activities taught in language other than English (unless justified by discipline)
- F/D: Project works and soft skills among those listed (2 x 3 cfu)
- E: Final examination (24 cfu)

Course Structure Diagram: <https://corsi.unibo.it/2cycle/artificial-intelligence/course-structure-diagram/piano/2021/9063/000/000/2020>



Soft Skills

- 89455 Patents & Trade Marks
- 73387 Creativity and Innovation
- 97326 Data Literacy
- 91935 Foundation of Entrepreneurship
- 94131 Health Literacy
- 81799 Project Management and Soft Skills
- 94133 Science of Climate Change and Climate Actions
- 94122 Soft Skills to be Effective at Work
- 94123 Sustainable Development and One Health

!! LIMITED SEATS AVAILABLE; FIRST-COME-FIRST-SERVED !!



Study plan

- **Who can submit the study plan?**

- Students enrolled in the ongoing academic year

- **When can I submit the study plan?**

- **Only in the following periods:**

- 1st period: 11th October 2021 – 12th November 2021
- 2nd period: 14th February 2022 – 11th March 2022

- **What are the rules?**

- The study plan must be filled out according to the Course Structure Diagram, referring to the academic year of your first enrollment
- Only exams in the study plan can be sat
- If one wants to sit an exam that is not in the study plan, one must first insert the exam in the study plan (which can only be done in the two periods indicated above)



Study plan: useful contacts

- **If you need help or guidance:**
 - on administrative/procedural issues:
Ms. Carlotta Viani
carlotta.viani@unibo.it
 - on the content of your study plan:
Prof. Federico Chesani
federico.chesani@unibo.it



Structure of the final examination

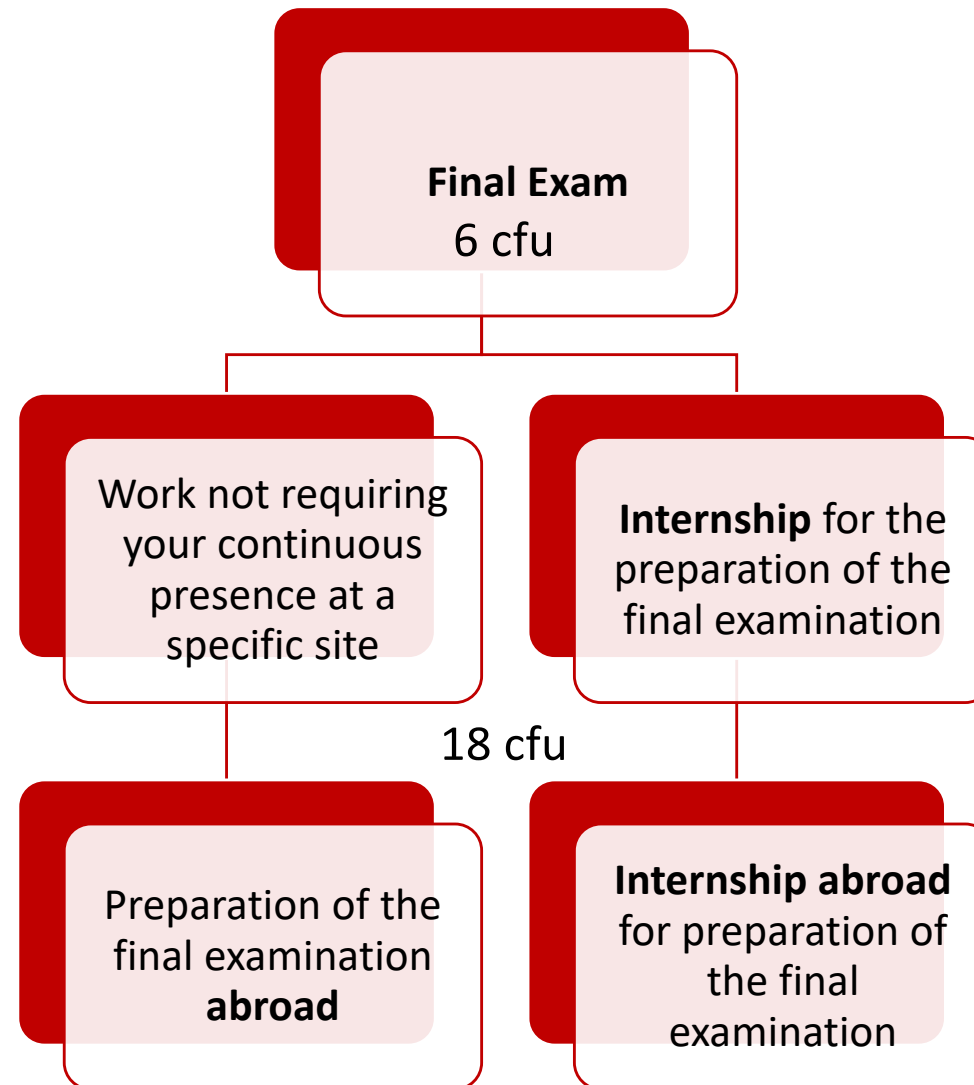

What about internship?

- **Internship for the final examination**

- It can be added in the study plan as of the 2nd year
- Students interested in it out must:
 1. add it to their study plan;
 2. find a hosting organization where to carry out the work
 - search is done autonomously
 - best to plan in advance
 - academic supervisor
- More info [here](https://corsi.unibo.it/2cycle/artificial-intelligence/internship-for-final-examination) (https://corsi.unibo.it/2cycle/artificial-intelligence/internship-for-final-examination)



Grants opportunity for thesis abroad

- 2 calls per year – Fall/late Spring (<https://bandi.unibo.it/>)
- Min 3 months – Max 6 months
- Students interested in it out must:
 1. find a hosting organization where to carry out the work
 - search is done autonomously
 - best to plan in advance
 - academic supervisor
 2. apply to the call (Studenti Online)
 3. present their project to the commission

If you need help or guidance:

on administrative/procedural issues:

Ms. Clarissa Caramagno

clarissa.caramagno2@unibo.it



Final examination

- To graduate, you must defend your final project (thesis)
 - Graduation dates in July, October, December, February, and March
- Before that, you must have:
 1. sat all the exams in your study plan and had them recorded
 2. paid all tuition fees
 3. filled-in the Alma Laurea questionnaire on Studenti Online
- The Student Administration Office will verify all requirements and contact you if there are any issues





COVID-19 - Resuming activities safely - [The measures adopted by the University of Bologna](#)

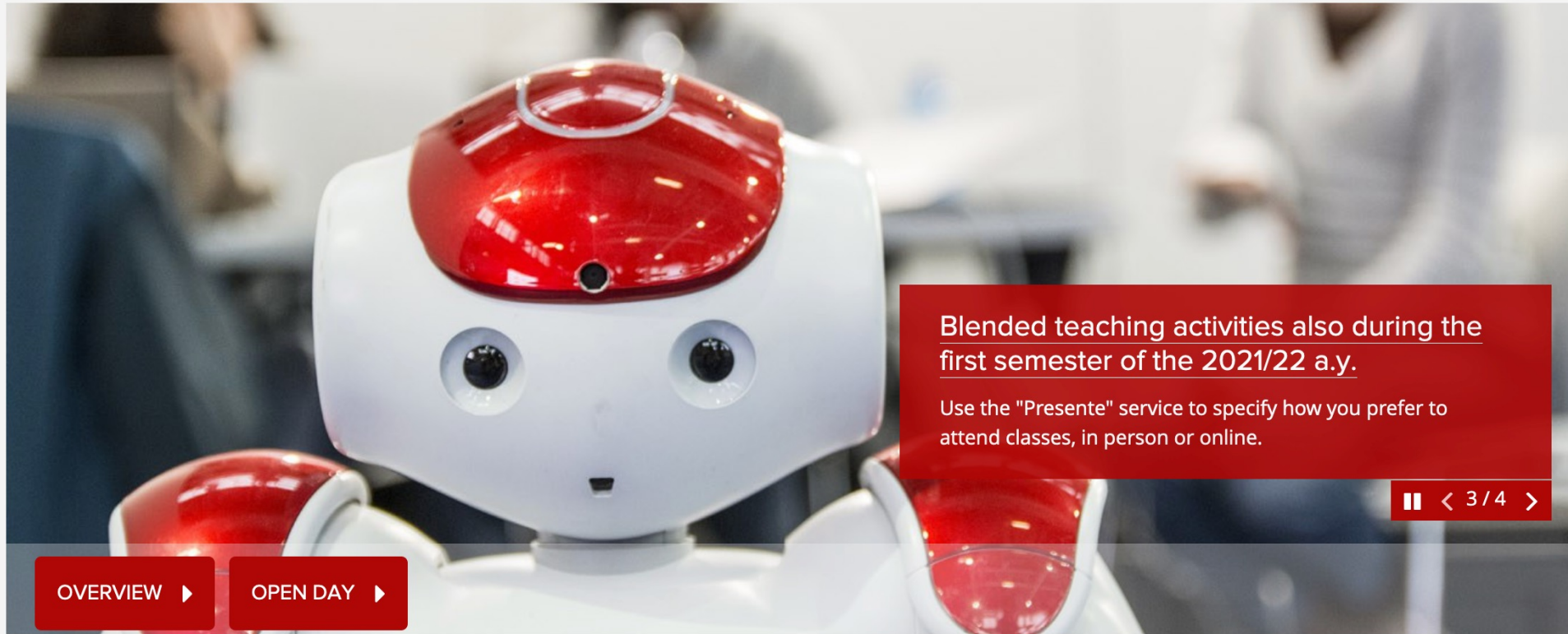

Blended teaching activities also during the first semester of the 2021/22 a.y.

Use the "Presente" service to specify how you prefer to attend classes, in person or online.

|| < 3 / 4 >

OVERVIEW ▶

OPEN DAY ▶



PROGRAMME TYPE

Laurea Magistrale (Second cycle degree/Two year Master - 120 ECTS)



PLACE OF TEACHING

Bologna



LANGUAGE

English



TYPE OF ACCESS

Open access with assessment of personal competencies



DEGREE PROGRAMME CLASS

LM-18 - Computer science
LM-32 - Computer systems engineering



DEGREE PROGRAMME DIRECTOR

[Paolo Torrioni](#)



DEPARTMENT

Computer Science and Engineering - DISI



LEARNING ACTIVITIES

[Course structure diagram](#)

Artificial Intelligence in Industry

Project Work in Artificial Intelligence in Industry

- **Michele Lombardi**

- 1st Semester (started Monday)

- The main goal is let students familiarize with **how to tackle industrial problems** (in a broad sense). The emphasis will be on **looking at the big picture**, picking the **right tools**, and **combining them**, using **both simple and advanced techniques**.

- The course will be delivered as **a set of simplified industrial use cases**, making extensive use of systems like Jupyter notebooks and Docker containers.

- The result is a sort of **cookbook**, from which the students will be able to **draw ideas** when faced with real-world problem.



What will I be able to do at the end of the course?

Generally:

- Identify and anticipate anomalous events
- Dealing with time series
- Combine some optimization and Machine Learning methods
- Build hybrid ML/statistical models
- Take into account constraints in Machine Learning models

And a few project examples:

- Understand and predict epidemic processes
- Diagnose medical conditions
- Design SotA packing system for industrial pallets
- Detect anomalies in wind turbines
- Estimating survival for liver transplants
- Model industrial equipment using ML and physics

81683 - INTERNET OF THINGS

(6 cfu)+

91286 - PROJECT WORK IN INTERNET OF THINGS

(3 cfu)

Professors' names:

Luciano Bononi (module 1) , email: luciano.bononi@unibo.it
<https://www.unibo.it/sitoweb/luciano.bononi/en>



Marco di Felice (module 2) , email: marco.difelice3@unibo.it
<https://www.unibo.it/sitoweb/marco.difelice3/en>



Period: 2° Semester (Feb 2022 – June 2022)



81683 - Internet of Things

- Main objective: to introduce the enabling technologies, protocols, software architectures and applications for the development of the emerging Internet of Things (IoT) paradigm (and its synergy with AI, Big/Open Data, Digital Twin, etc.)
- Introduction to IoT systems: definitions, applications, enabling technologies
- IoT components: **from sensors to gateway**
 - (Arduino, STM32 Nucleo, ESP8266) (BLE, IEEE 802.15.4, Z-Wave, etc.), (LoRA, Dash7, Spirit, etc.), (6LoWPAN, RPL), etc.
- IoT components: **from gateway to cloud.**
 - XMPP, CoAP, MQTT, AMQP, WebSocket, cloud/fog/edge computing, IoT Platforms, IoT and Big data
- IoT components: **from cloud to applications.**
 - Web of Things and Semantic Web 3.0, Machine learning principles, sensor data analysis, AllJoyn, Google Thing, Apple HomeKit, IoT Platforms (e.g. AWS IoT)
- IoT Open **Issues and bottlenecks.**
 - privacy, security, energy efficiency, scalability



What will I be able to do at the end of the course?

- to understand the **architectures and methodologies** at the basis of the Internet of Things (IoT) and IoT Platforms
- to understand **network protocols**, integration of mobile and pervasive **end-devices, middleware** platforms for M2M-based **IoT systems, edge/distributed/gateway** computing principles, new services, **service platforms** and **innovative application** scenarios
- create/exploit **synergy** with Web Of Things, AI, Machine learning, Big/Open Data, Digital Twin, Mobile Apps, etc.
- Final Exam: Seminar + Project



IoT Prism Lab

Research Lab at University of Bologna

More details here:

<http://iot-prism-lab.nws.cs.unibo.it/>

<https://site.unibo.it/iot/en/teaching-1/the-iot-course>



What will I be able to do at the end of the course?

- Projects (some more examples in next slides)
 - Multiprotocol IoT Bridge Platform (data visualization, storage, bridging)
 - SenSquare: IoT service middleware
 - Arrowhead: toolchain for Industrial IoT and Service Oriented Architectures
 - WoT and Digital Twin
 - Mobile Crowdsensing and Crowdsourcing platforms
 - Activity recognition and context awareness
 - Drones and autonomous systems (e.g. drone swarms)
- Systems' Design and frameworks development and adoption
- Thesis in international Projects and Collaborations
 - e.g. <http://iot-prism-lab.nws.cs.unibo.it/proposals/>
- PhD programs, e.g. Computer Science (CS), Data Science (DS), or Structural and Environmental Health Monitoring and Management (SEHM2)

What will I be able to do at the end of the course?



Human Activity Recognition
Edge AI + embedded systems
Author: Alessandro Ghibellini

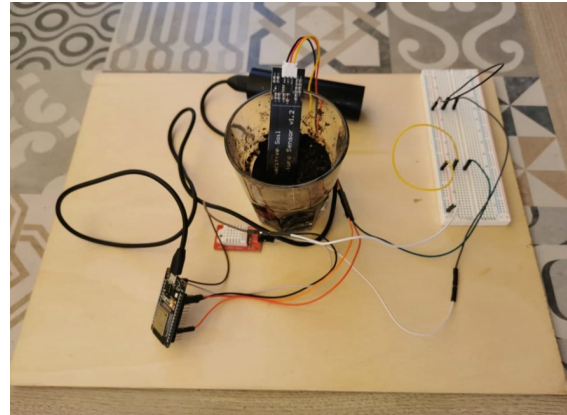

Smart Pot System
Remote monitoring of indoor gardens
Author: Damiano Bellucci

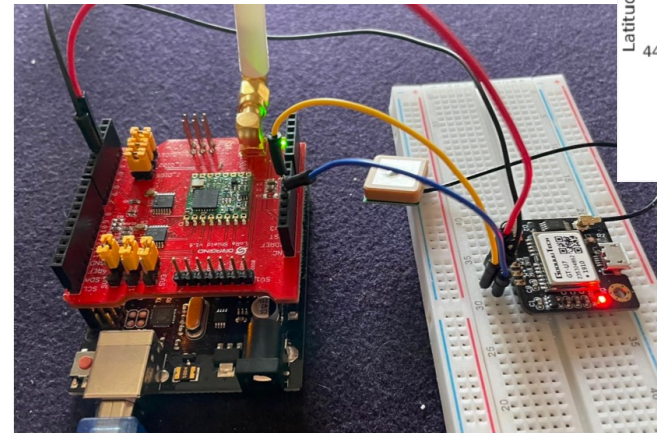

Low-power tracking of bicycles
LoraWAN stack

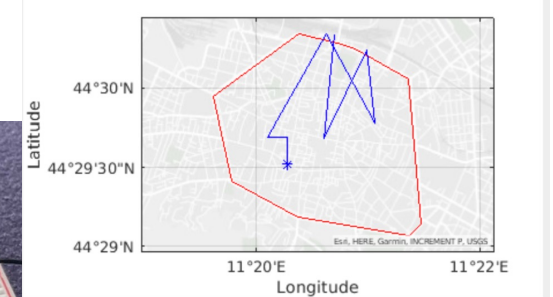

What will I be able to do at the end of the course?

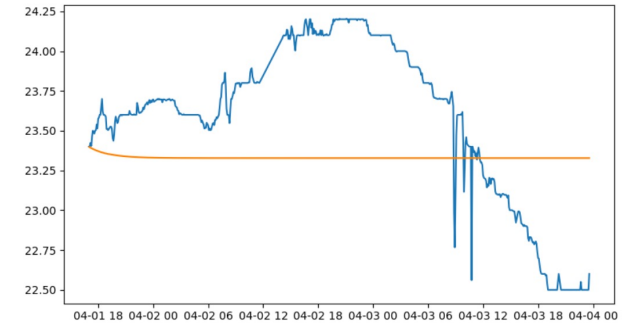
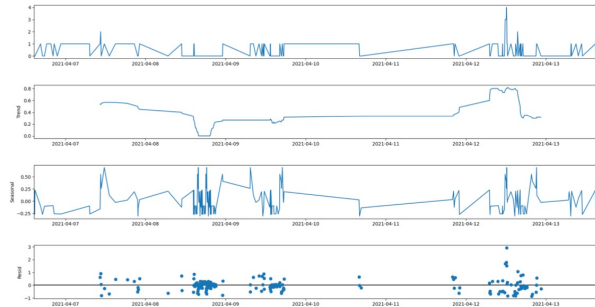
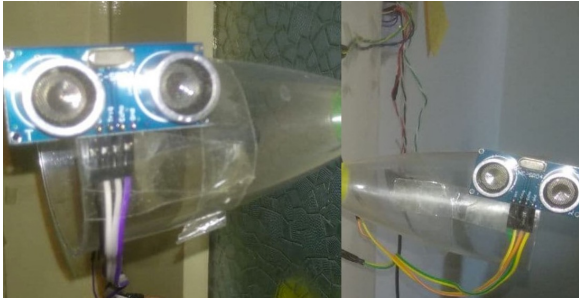

SafeLab

Access Control and People counter with proximity sensors and the Web of Things

Author: Christian Castiglione

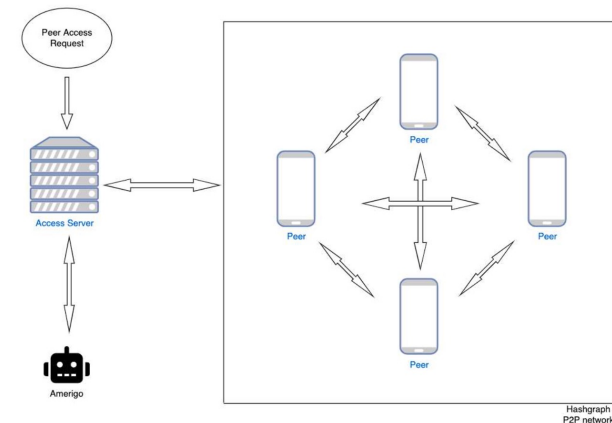
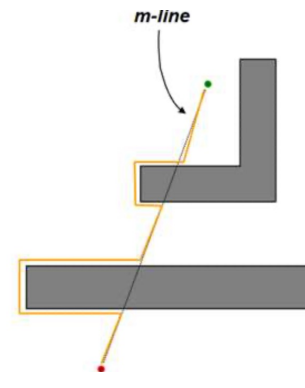
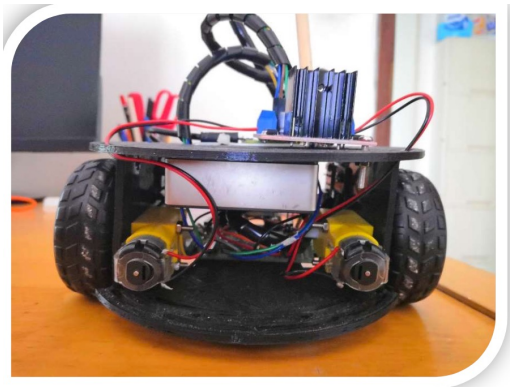

Amerigo

Self-steering, autonomous robot, Block-chain enabled (Hedera Hashgraph)

Author: Bruno Quintero Panaro, Nunzio Maccarrone

Complex Systems and Network Science

Ozalp Babaoglu

Dipartimento di Informatica — Scienza e
Ingegneria Università di Bologna

www.cs.unibo.it/babaoglu

What is this course about?

- Survey the mathematical foundations, goals and methodologies of complexity science which is an interdisciplinary study whose core disciplines include
 - Mathematics
 - Physics
 - Computer science
 - Biology
 - Sociology
- Tries to answer a set of questions about the way natural, artificial and technological systems work
- Modeling as a core methodology



Questions of complexity

- Why did the Dow Jones stock index drop 1,175 points on Monday, 5 February 2018?
- Why did the forty-year hegemony of the Soviet Union over Eastern Europe collapse within a few months in 1989?
- How did the first living cell emerge from a primordial soup of amino acids and other simple molecules four billion years ago?
- How can a 1kg lump of gray matter give rise to qualities such as feeling, awareness, thought and creativity?

Examples of complex systems

- Social insects
- The human brain
- The mammalian immune system
- Economies, financial markets
- Cities, traffic
- Data centers
- The Internet
- Peer-to-peer systems
- The World Wide Web



Common properties

- Simple components — agents, actors
- Decentralized control — no distinguished “master”
- Nonlinear interactions — components act autonomously but interact with other components directly or indirectly
- Emergent behavior — the global system exhibits properties that cannot be derived or predicted from understanding behaviors of individual components

Social insects

- When considered in isolation, ants and termites exhibit extremely primitive behavior lacking any hint of intelligence or purpose
- Yet, considered in large numbers, they are capable of accomplishing remarkable tasks without any central control such as foraging looking for food
- Or building bridges
- And termite mounds



Emergent behavior Starling murmurations



Networks and network science

- Interactions among agents is central to complex systems
- Networks allow us to model these interactions
- Networks play a fundamental role in the transmission of information, transportation of goods, spread of diseases, diffusion of innovation, formation of opinions, adoption of new technologies
- Understanding the structure and dynamics of these networks is essential for understanding why certain technologies dominate their competitors, or why a certain videos go viral while others don't

Course evaluation

- Research paper presentation (40%)
- Project written report (50%)
- Project discussion (10%)



Multi-Agent Systems

Project Work in Multi-Agent Systems

- **Professors:** Andrea Omicini & Roberta Calegari
- **Period:** February-June 2022
- **Main objective:** Design and build intelligent systems as multi-agent systems



What will I be able to do at the end of the course?

- Understand the conceptual and technical *foundation* of (intelligent) multi-agent systems
- Model complex *computational* and *socio-technical* systems in terms of agent-oriented abstractions
- Build build complex computational and socio-technical systems using agent-oriented *technologies* and *methodologies*
- Design and engineer **intelligent systems as multi-agent systems**, by integrating techniques and methods from artificial intelligence in an effective and methodologically-sound way
- FINAL EXAM: **PROJECT** on a student's selected topic in the area of agent-based intelligent systems spanning from theory to implementation
 - Some examples
<https://apice.unibo.it/xwiki/bin/view/Courses/Mas2021Projects>

Data Mining, Text Mining and Big Data Analytics Project Work

Professors: Gianluca Moro, Stefano Lodi, Claudio Sartori

Course Timetable 2021

- Gianluca Moro: Module of Text Mining from Sep 29, to Dec 17
- Stefano Lodi: Module of Big Data Analytics from Nov 17, to Dec 22
- Claudio Sartori: Module of Data Mining from Nov 30, to Dec 22

Main objective: Designing and Implementing Data Analysis and Knowledge Discovery for Big Data and Text Corpora

- At the end of the course, the student understands how a possibly very large set of data can be analysed to derive strategic information and to address "data-driven" decisions. The student has a knowledge of the main data-mining tasks such as data selection, data transformation, analysis and interpretation, with specific reference to unstructured text data, and with the issues related to analysis in "big data" environments.
- <https://www.unibo.it/en/teaching/course-unit-catalogue/course-unit/2021/446610>



Big Data Analytics module

What will I be able to do at the end of the course?

- Configure the big data distributed processing framework Apache Hadoop for a small cluster of computers
- Write Python scripts that carry out simple data analyses of large data sets using the Apache Hadoop implementation of the MapReduce programming model
- Write data transformation scripts using the Python API to the Apache Spark big data analytics engine
- Write Python scripts in Apache Spark which compute Machine Learning models, using the Apache Spark Machine Learning library MLlib
- Understand the distributed programming techniques for writing Python distributed programs using the unstructured API of Apache Spark, from examples of data mining algorithms implemented in the API

Data Mining module

What will I be able to do at the end of the course?

- Understand the CRISP methodology for the definition of a Data Mining process
- Given a Data Mining problem, define the steps for the solution according to the CRISP methodology
- Use the machine learning techniques learned in other courses/modules as a part of the data mining process
- Evaluate the effectiveness of the machine learning techniques used
- Understand the concepts and the architectures of Data Warehouses
- Read and understand the schema of a Data Warehouse
- Understand the concepts of Data Cube and OLAP

This module is the natural complement of a course/module of Machine Learning

Text Mining module

What will I be able to do at the end of the course?

- Design and implement knowledge discovery tasks for text corpora
 - Text representation, indexing and similarity, identification of relevant terms
 - Ranking-based Information retrieval and evaluation methods
 - Dimensionality reduction and feature selection methods for textual data; lab
 - Novel latent semantic analysis method for discovering underlying explanations of phenomena; lab: discovering explanations of aircraft accidents from aviation reports
 - Text classification, topic analysis, sentiment analysis & opinion mining, lab
 - Memory-based neural networks for text mining
 - Text latent representation with deep metric learning and SOTA language models
 - Neural self-supervised information retrieval; lab on cross-modal retrieval from very large repository of texts and images with quadratic and linear attention (*seminar*)
 - Extractive and abstractive text summarization of long docs in low-resource regimes; lab on summarization of legal cases (*seminar*)
 - Learning knowledge graphs from unstructured text; lab on extracting n-ary relations from medical literature for modeling & explaining biological processes (*seminar*)



Knowledge Engineering

Project Work in Knowledge Engineering

- **Professors:** Valentina Presutti and Andrea Giovanni Nuzzolese
- **Period:** first
- **Main objective:** the objective of the course is to provide the students with advanced semantic modelling capabilities and a proper knowledge of the state of the art in ontology and knowledge graph engineering.
- The project as well as the practices during classes make the students face realistic project scenarios and become expert in using the available methods and tools for knowledge engineering



What will I be able to do at the end of the course?

- Analysing and formally modelling problems
- Modelling ontologies and knowledge graphs
- Querying and reasoning over knowledge graphs
- Evaluating the quality of an ontology/knowledge graph
- Integrating large, distributed and heterogenous datasets based on semantic technologies
 - E.g. using knowledge extraction from text

Examples of projects:

- A smart music playlist engine based on semantic relations between songs
- Modeling and integrating data from sensors capturing environmental parameters to support monitoring the conditions of Italian seas
- Modeling and creating a multimodal knowledge graph that links visual, factual and linguistic data
- Comparing translations across multiple languages by formal reasoning on their knowledge graph representations



Blockchain & Cryptocurrencies

- **Professor:** Stefano Ferretti
- **Period:** I semester
- **Main objective:**
provide an introduction to the main technologies that are currently related to the “blockchain” keyword:
 - distributed ledgers
 - decentralized file systems
 - smart contracts
 - cryptocurrencies, fintech and other applications



What will I be able to do at the end of the course?

At the end of the course

- The student knows the relevant themes related to blockchain technologies, cryptocurrencies, smart contracts and novel applications that can be built over the blockchain
- The student is able to develop simple smart contracts that can be deployed on a blockchain

91259 - ARCHITECTURES AND PLATFORMS FOR AI

Project Work in Architectures and Platforms for AI

- **Professor:** Luca Benini (DEI), Gianluigi Zavattaro (DISI)
Benini → module 1, Zavattaro → module 2
- **Period:** 23/9-5/11 (module 1) – 23/9-16/12 (module 2)
- **Learning Outcomes:** to gain a good understanding of:
 - the requirements of machine-learning workloads for computing systems,
 - the main architectures for accelerating machine learning workloads and heterogeneous architectures for embedded machine learning,
 - the most popular platforms made available by cloud providers to specifically support machine/deep learning applications.



What will I be able to do at the end of the course?

- Understand ML and DL as a workload for a computer architecture and gain the ability to assess the computational and memory requirements of modern deep neural network (DNN) topologies
- Acquire working knowledge of optimization approaches to improve computational efficiency on DNN workloads: efficient algorithms and iso-accuracy transformations (Winograd, FFT...), approximation techniques (sparsification and training)
- Optimize DNN computations for execution on RISC-V cores, through a range of ISA and hardware architecture-aware software optimization techniques
- Understand parallel programming patterns (embarrassingly parallel, decomposition, master/worker, scan, reduce)
- Gain practical knowledge of Shared-Memory parallel programming with OpenMP, with application examples from the field of Machine Learning

User Experience Design

Project Work in User Experience Design

- **Professor:** Fabio Vitali
Department of Computer Science (DISI)
- **Period:** 20 september – 20 December 2021
- **Learning Outcomes:** *Ability to design, implement and evaluate software systems in terms of practicality, experience, affection, meaning and value that they may have on the target audience. Characteristics such as ease of use, usefulness and efficiency are fundamental for the positive evaluation of the user experience of the system.*
A seminar specifically for AI students is being held, about explanations and explainability in complex systems and Artificial Intelligence systems.



What will I be able to do at the end of the course?

- You will be able to plan the design of the User Experience and Usability of a complex system, including Artificial Intelligence Systems.
- You will be able to identify and characterize users, tasks and contexts of use of such systems, and establish metrics for the evaluation of their *Quality in Use*.
- You will be able to carry out inspection and evaluation tasks of your designs, and verify whether and how much they match the expected target metrics.
- You will be able to plan the design of the explanation part of a complex system, , including Artificial Intelligence Systems, so as to match existing legal, ethical and commercial requirements of such systems.

Autonomous and Adaptive Systems

- **Professor:** Mirco Musolesi
- **Period:** February-June 2022
- **Learning objectives:** The goal of this module is to provide a solid introduction to the design of autonomous and adaptive systems from a theoretical and practical point of view. Topics will include:
 - design principles of adaptive and autonomous systems and intelligent machines;
 - Reinforcement Learning;
 - game-theoretic approaches to cooperation and coordination;
 - models of social systems (human, artificial and hybrid);
 - bio-inspired learning systems;
 - complex adaptive systems;
 - artificial intelligence and creativity;
 - ethical implications of AI/autonomous systems.



What will I be able to do at the end of the course?

- You will master the theoretical principles at the basis of Reinforcement Learning and be able to select the right algorithm for a variety of practical application scenarios.
- You will be able to design and implement state-of-the-art algorithms. Examples include the implementation of a Deep Reinforcement Learning agent that is able to play a videogame or a board game like Chess and Go or a simulation of agent societies using Multi-agent Reinforcement Learning.
- You will be able to understand the game-theoretic mechanisms at the basis of human, artificial and hybrid societies, including phenomena like the emergence of cooperation.
- You will be able to use TensorFlow/Pytorch (or other similar frameworks) for implementing any (Deep) Reinforcement Learning algorithms from scratch.
- The instructor also offers research-oriented dissertations on the topics discussed in this module. There is also the possibility of preparing the dissertation at University College London (UCL) potentially (the instructor is affiliated with UCL).

Cybersecurity

- **Professor:** Michele Colajanni
- **Period:** First semester
- **Language:** English
- **Main objective**

In a digital world, every activity is vulnerable to cyber attacks. At the end of the course the students can know and evaluate the most dangerous cyber threats to the society and to specific organizations and industries. Moreover, they are expected to be able to design, build and manage secure systems and applications by adopting modern preventive and defensive methodologies, strategies and technologies. Modern applications of AI to cybersecurity will be also covered.

- **Prerequisites**
 - Fundamental courses characterizing a Bachelor in Computer Science or Computer Engineering: systems, networking, software
 - Some knowledge about traditional approaches to information security (authentication mechanisms, secure protocols, firewalls) may help

Scalable and Reliable Services

- **Professor:** Michele Colajanni
- **Period:** Second semester
- **Language:** English
- **Main objective**

Modern digital services have to meet various requirements in terms of performance, scalability and reliability. We analyze the whole lifecycle of high-quality services, from design to deployment, testing and operation. In each phase, we aim to provide the students with the ability to gather and analyze data, to identify sources of outages and critical dependencies, and to avoid bottlenecks and single points of failure. Finally, we expect students to be prepared to evaluate and discuss alternative solutions and justify investment in support of business services.

- **Prerequisites**
 - Cloud systems
 - Computer networks
 - Information systems
 - Software programming

Social Network Analysis

- **Professor:** Saverio Giallorenzo
- **Course website** <https://saveriogiallorenzo.com/teaching/#na>
- **Period** Sep. 23rd, 2021 to Oct. 29th, 2021
- **Description**

The objective of the course is to equip students with a working knowledge on both a) the field of **Network Analysis**, its principles, practice, and usages (e.g., in computer science, forensics, archeology, literature, history, science of religion, etc.), and b) **Network Analysis Research Design**, focussed on the scientific process and the elements of a network analysis investigation.
- The course will provide students with the knowledge necessary to conduct the project exam: define, structure, and pursue their own network analysis research, on a topic of their choice — agreed with the teacher.



What will I be able to do at the end of the course?

- **Recognise** networks and network data;
- **Collect** and **manage** network data, from both a technical and technological standpoints (data formats, algorithms, and software for network data management);
- **Investigate** network data by following the principles behind known measures and metrics for networks and by using those in practice through software that automates their application;
- **Organise** network studies following the principles of the scientific method.

Machine Learning for Computer Vision

- **Professor:** Samuele Salti
- **Period:** first semester (from Sep 20, 2021 to Dec 20, 2021)
- **Main objective:** Train the students to master the most popular modern machine-learning approaches to computer-vision tasks, with particular reference to specialized deep-learning architectures. At the end of the course, the student has both the theoretical understanding and the practical skills required to develop state-of-the-art image analysis systems for real-world applications.

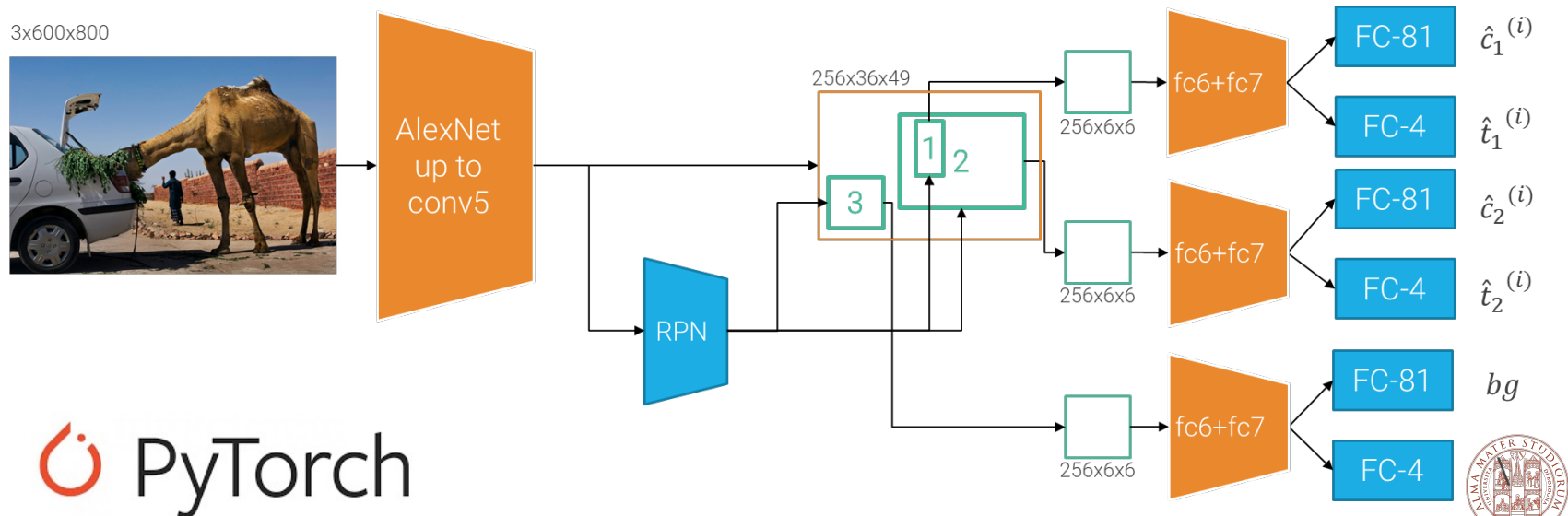

What will I be able to do at the end of the course?

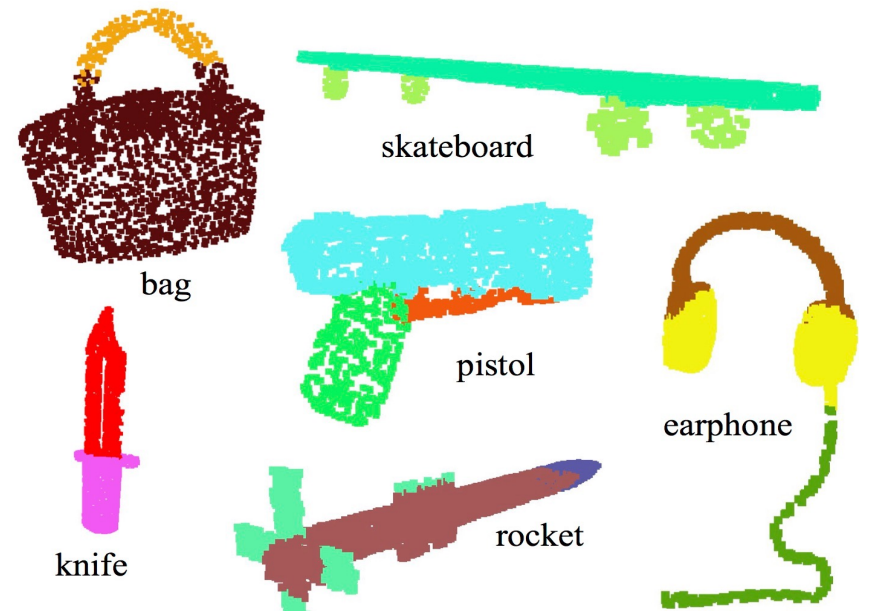
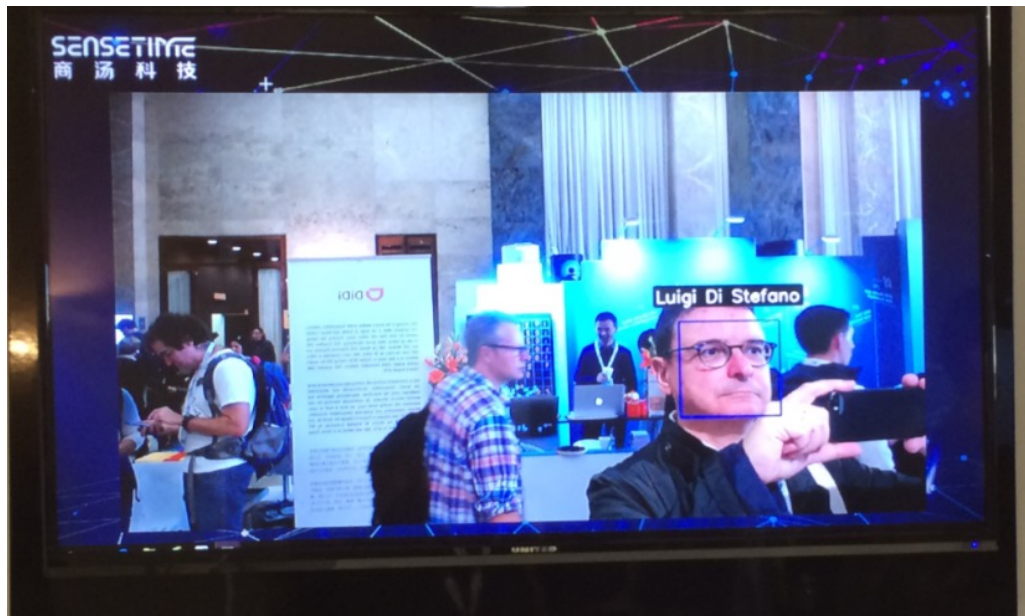
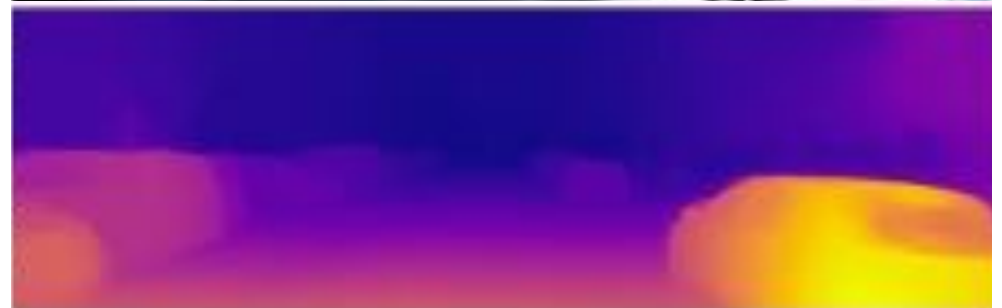

Multimedia Data Management - 6 cfu

- **Ilaria Bartolini**

Department of Computer Science and Engineering (DISI)
Multimedia Database Group
Alma Mater Studiorum, Università di Bologna

- **Period II:** February - June 2022

- **Main objective:**

Facilitate and improve the “access” to very large unconventional data (Big Data), notably multimedia (MM) data (e.g., textual documents, image/video/audio collections, etc.) for general, non-expert users

- **Project Work in Multimedia Data Management - 3 cfu**



What will I be able to do at the end of the course?

- At the end of the course, the student will have the knowledge and skills required for an effective and efficient management of MM data, with particular attention to the problems of
 - MM data representation
 - MM data retrieval models
 - Interaction paradigms between the user and the MM system, both for purposes of data presentation and exploration
- The student understands the architecture of traditional and advanced MM systems and services, search engines, social networks, and recommendation systems

facebook

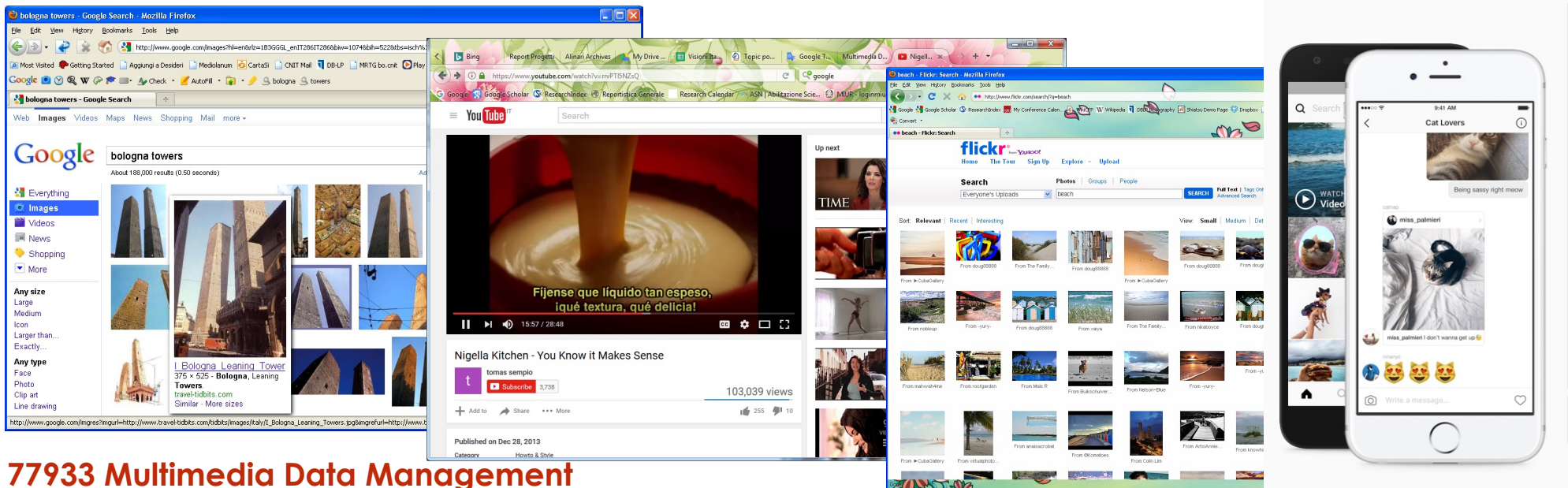

Distributed Autonomous Systems

- **Professor's name:** Giuseppe Notarstefano and Ivano Notarnicola
- **Period:** second cycle.
- **Main objective:** learn how to model a multi-agent system and how to implement distributed algorithms to solve relevant application problems arising in cyber-physical networks or autonomous robots and vehicles.



What will I be able to do at the end of the course?

Model a distributed multi-agent system to cooperatively solve global tasks via peer-to-peer communication and local computation

Learn state-of-the-art distributed algorithms for learning, decision making and control

Apply them to practical examples in machine learning and data analytics, decision making, and cooperative autonomous robots

Code in Python distributed learning and control algorithms for multi-agent systems and use novel Python toolboxes for distributed optimization and cooperative robotics.



ALMA MATER STUDIORUM
UNIVERSITÀ DI BOLOGNA

Thank you!

Questions?